

APRICUS ECO MULTI-USE 300L CYLINDER

OUTDOOR OR INDOOR INSTALLATION



SPECIALLY DESIGNED FOR ALL EFFICIENT HOT WATER TECHNOLOGIES:

- CO₂ hot water heat pumps
- Solar hot water systems
- Central heating heat pumps (requires HX & pump added)

HOT WATER CYLINDER

Capacity	300L
Dimensions	650w x 1740h (mm)
Cylinder	Duplex stainless steel
Casing	Frosted grey, powder-coated zinc alum, outdoor cased
Heat loss	1.95 kWh / 24 hr. Lowest heat loss in New Zealand for 300L
Insulation	75 mm polyurethane. Zero ozone depletion
Warranty	5 Years

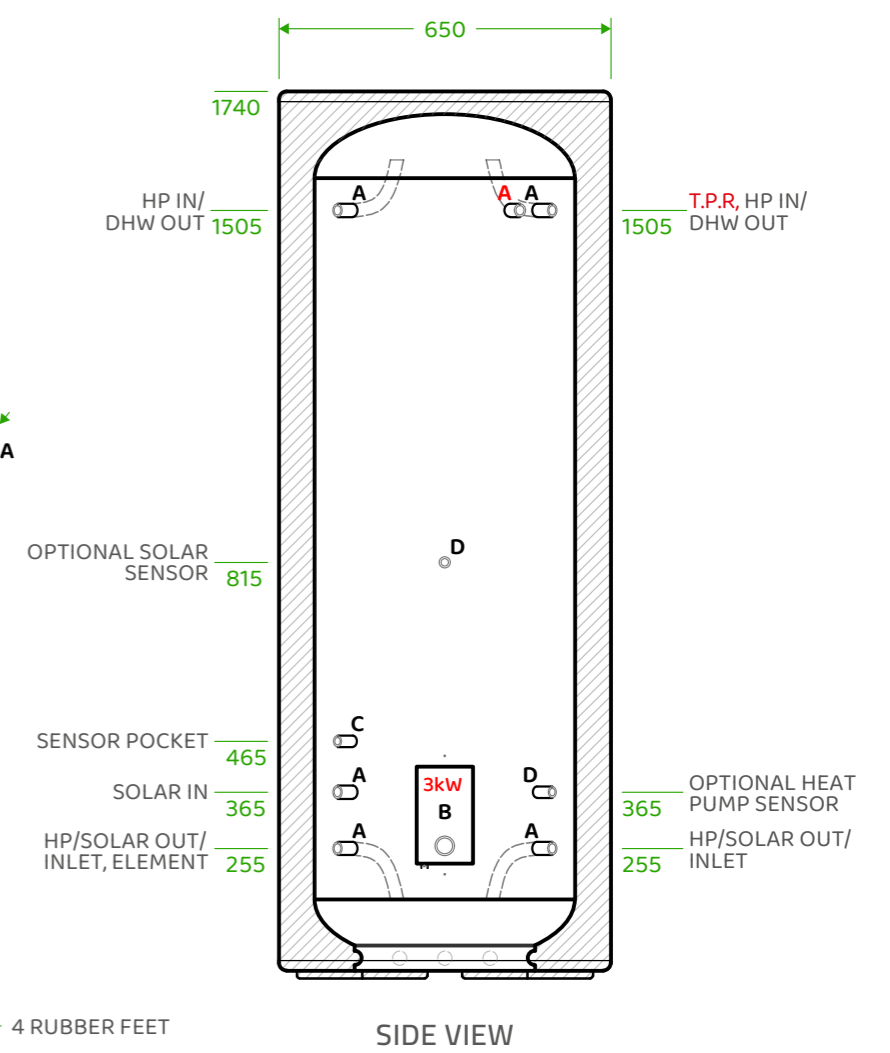
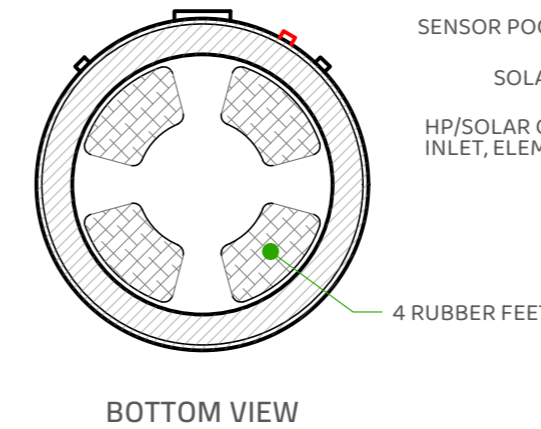
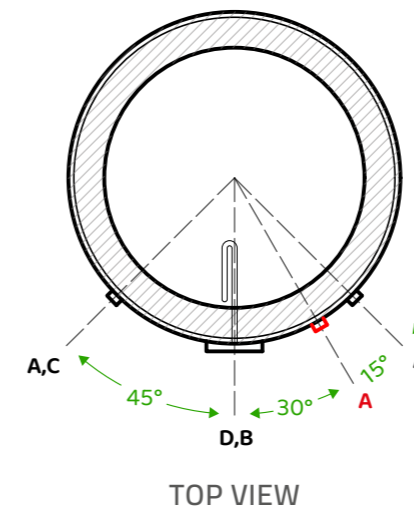

KEY (all dimensions in mm)

- * A = 20 mm SOCKET
- * B = 25 mm SOCKET, 3kW E&T
- * C = 15 mm SOCKET, SCREW-IN POCKET
- * D = 15 mm SOCKET, BLANKED

CONTACT US TODAY

07 312 3382

info@ecohotwater.co.nz

ecohotwater.co.nz